

Gallery

Cable systems for the suspension
and/or tensioning of exhibits

- Galleries
- Museums
- Exhibitions

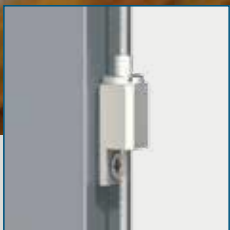
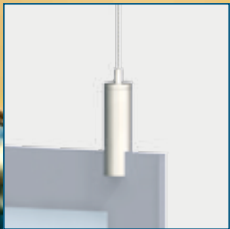

REUTLINGER[®]
systematic suspension

From a traditional workshop into a global high-tech company

»Technology should help us reach our goals. Therefore REUTLINGER constantly strives for logic and simplicity in all our products. Every detail must be functional and each function must make sense.«

Wolf Reutlinger, who has led the company since 1987, continued this tradition of craftsmanship while initiating innovative processes which opened up new applications and markets.

More than meets the eye

The use of REUTLINGER fastening attachments always results in permanent connections.

This is the effect guaranteed by the self-locking mechanisms inside our holders. The elements devised specifically for this purpose are based on the following principle: the higher the load – the greater the clamping force. For safe working loads (WLL) up to 500 kg.

World-wide success through constant product improvement

By continually expanding the range of our products we were able to dominate the world market for suspended lighting fixtures within a few years. Today we are proud to call virtually all manufacturers of high-quality lighting fixtures – as well as the automotive industry, sign- and shelf manufacturers, galleries and museums – among our regular customers.

Customized systems for galleries and exhibits

In the last few years REUTLINGER – in cooperation with design and exhibition experts – has developed specialized tensioning and suspension systems for all variants of exhibits, galleries and museums.

These REUTLINGER solutions offer important advantages over other well known suspension systems:

- **Saving time**
The holders can be installed without any tools whatsoever, and are infinitely adjustable.
- **Saving space**
REUTLINGER suspension systems allow objects to be hung from any point on the ceiling, not just from walls.
- **Emphasizing design features**
REUTLINGER holders are also distinguished by their modern design and discreet appearance. This draws attention to the exhibits, not the suspensions.
- **Safety**
The use of REUTLINGER components guarantees the safe installation of exhibits as well as the safety of visitors.

Show opens in one hour – and not a single exhibit has been hung?

With the versatile REUTLINGER gallery system that wouldn't be a problem: the simple installation and infinite adjustability – without any tools – lets you hang and arrange everything within a few minutes.

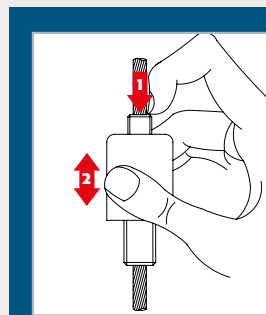

- The cable is entered into the holder from the top.
- As soon as the downward movement of the cable stops, the holder firmly clamps it.
- After un-loading the cable, the holder can be released by pressing on the plunger (1) with your fingertip; it can now be moved again to any spot on the cable (2).

The function of REUTLINGER cable holders is based on a simple principle: the higher the load – the greater the clamping force.

Contents



REUTLINGER: The only TÜV-GS certified holders



The German TÜV is internationally respected as a rigorous testing institution that's highly trusted by producers and consumers – especially for technical products.

The highest and most comprehensive level of TÜV testing is GS – certification, denoting safe equipment, and recognizable by the well-known blue sticker.

REUTLINGER is the world's only manufacturer of cable suspension systems that has succeeded in complying with the demands of GS certification with every product line. Our promise: safety confirmed by the TÜV.

Attachment Vertical Cables

Suspension on walls

Single-unit gallery track	04
Two-part gallery track	06
Hinged tensioners	08

Tensioning on walls

Hinged tensioners & hinged holders	08
------------------------------------	----

Suspension from ceilings

Ceiling attachments	09
Tracks & tensioners	10

Tensioning between floor and ceiling

Tracks, tensioners and holders	12
Tensioners and holders	14

Object attachment to vertical cables

Applications	16
Cable holders	18
Display holders and cable guides	19
Display connectors and cable guides	20
Overview of coupling options	21

Cables (wire-ropes)

Cable types	22
Terminals	23

Information & Service

Functional mechanisms	02
Safety points	21
Contact	24

Suspension on walls

► Single-unit gallery track

The classic solution: single-unit gallery tracks

Who isn't familiar with this classic gallery track? The simple yet ingenious solution for flexibly and discreetly hanging pictures or other exhibits on the walls of galleries. Usually the track is installed to run around the complete exhibition space. The laterally inserted vertical cables, from which the exhibits are suspended, can be horizontally moved to any desired position along the wall.

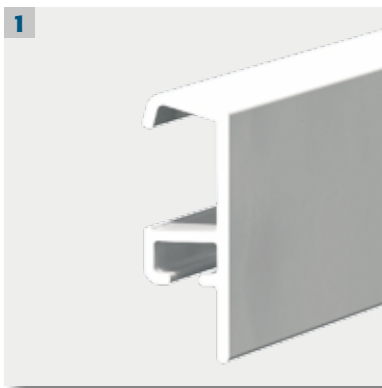

1 Single-unit gallery track white

Aluminum profile white,
Length 3000 mm, includes
6 gliding hooks, attaching parts
and instruction sheet,
Art. no. 029.005.213



2 Single-unit gallery track black

Aluminum profile black,
Length 3000 mm, includes
6 gliding hooks, attaching parts
and instruction sheet,
Art. no. 029.005.266

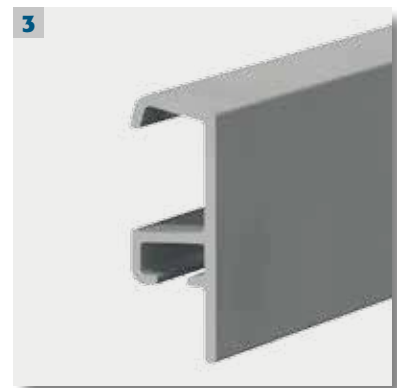

3 Single-unit gallery track silver

Aluminum profile silver
Length 3000 mm, includes
6 gliding hooks, attaching parts
and instruction sheet,
Art. no. 029.005.211

Simple attachment to walls



1. Insert suitable dowel



2. Screw in screw, clamp,
washer and plate



3. Hang track into top edge
of holding clamp



4. Press in bottom edge
of track until it snaps in.
That's it.

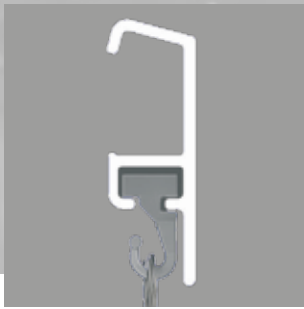

Coupling with gliding hook, inserted laterally. See picture No. 6

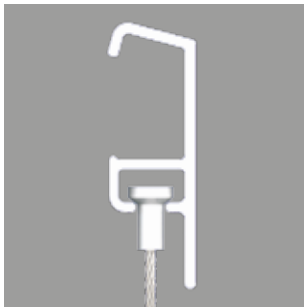

Coupling with T-sleeve 02, inserted laterally. See page 23

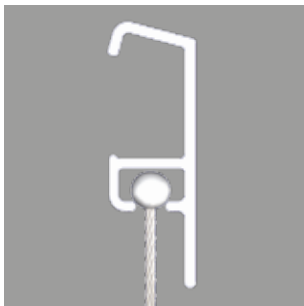

Coupling with ball sleeve 35, inserted laterally. See page 23

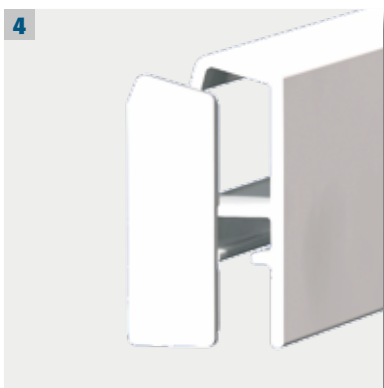
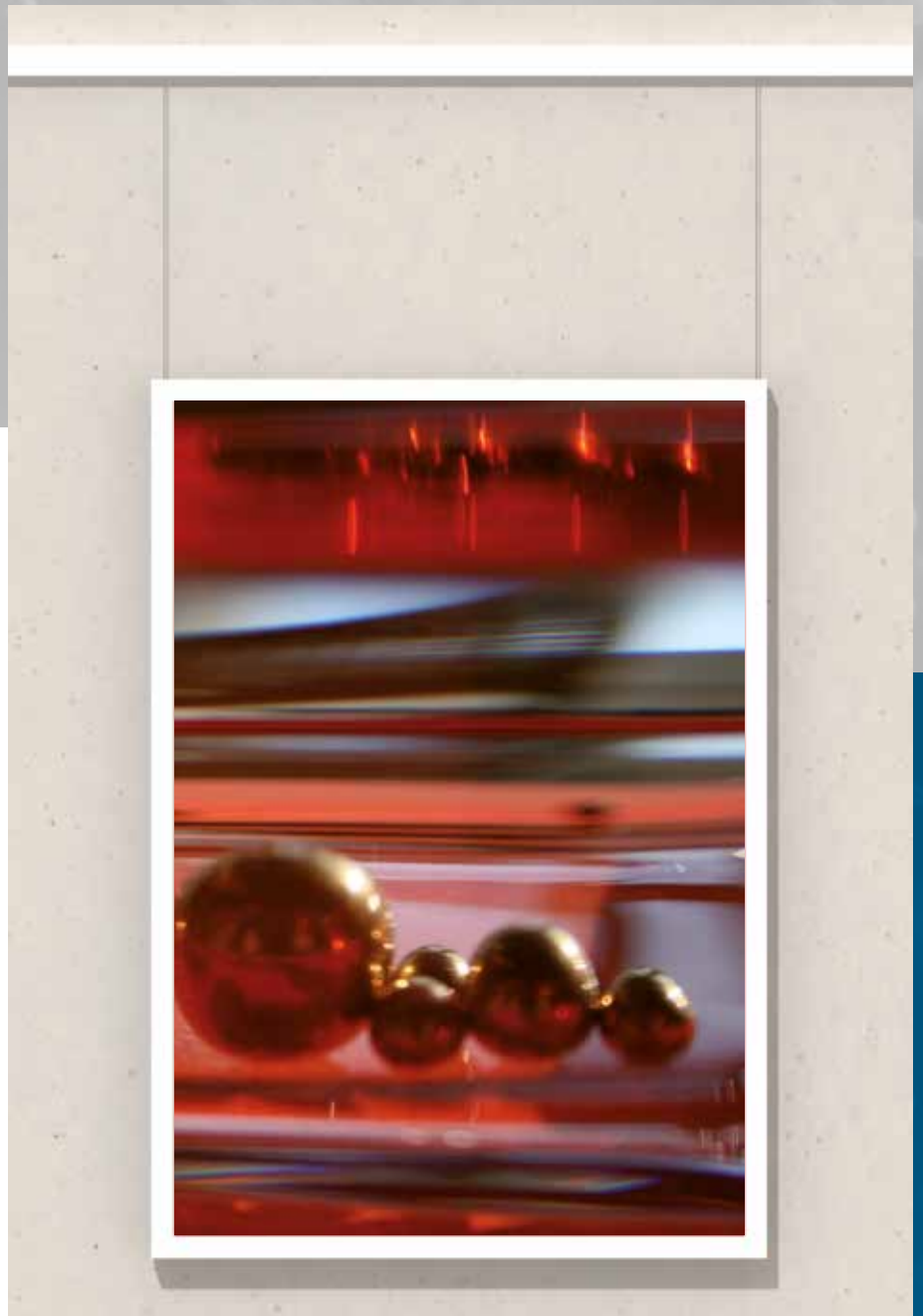

4 Endcaps
For single-unit gallery track; set contains left and right pieces; PVC white, Art. No. 029.005.217
black, Art.Nr.: 029.005.290
silver, Art.Nr.: 029.005.291

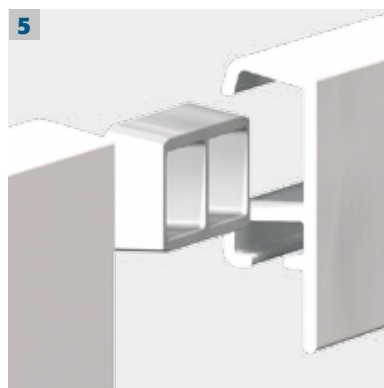

5 Track connector
For single-unit gallery track; PVC white, art. no. 029.005.219



6 Gliding hook
For single-unit gallery track; die-cast zinc.
Art. no. 029.005.215

Suspension on walls

► Two-part gallery track

Flexible Design: Two-part gallery track

The two-part gallery track works just like the single-unit version.

But its removable covering panel can be painted, making it easy to color-coordinate the track with the venue and/or the exhibits.

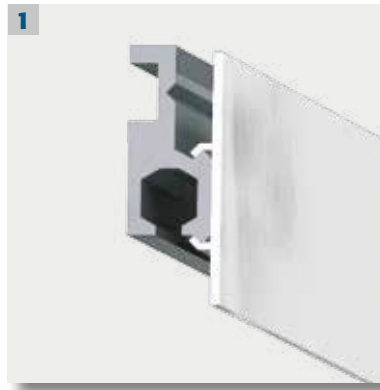

1 Two-part gallery track with panel

Aluminum profile with flexible covering panel in white PVC;
Length 2030 mm
Art. no. 193.005.265



2 Endcap

For two-part gallery track, for pasting/gluing; usable on left and right ends
Art. no. 029.005.864

Simple installation on walls*



1. Drill hole in track



2. Insert suitable dowel



3. Fasten track with screw



4. Press on flexible panel.
Finished!

* Screws and dowels not included!



*Coupling with ball sleeve 35;
for product information
see page 23*



*Clean finish: track with
inserted end-cap; see page 2,
illustration No. 2*

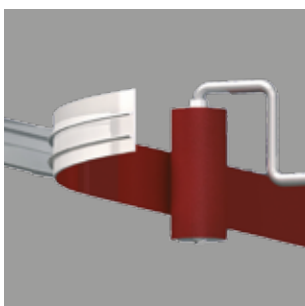

*Covering panel of two-part
gallery track is easily painted
in color of choice.*

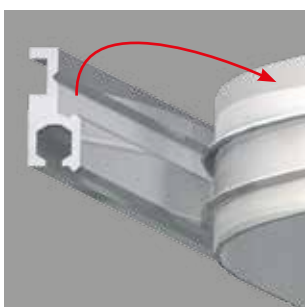

Track with removable panel.



Suspension/tensioning on walls

► Hinged holders and hinged tensioners

The alternative to gallery tracks

When design considerations are more important than horizontal adjustability, then suspension or tensioning on walls by using hinged holders or hinged tensioners offers an impressive alternative.

Suspension or tensioning?

These parts can be used for suspensions (holder at the top) as well as for tensioning (tensioner at the top, holder at the bottom).



1 Hinged tensioner ellipse

Suitable for vertical, horizontal and diagonal applications; with elliptical cap; with free-wheeling hub for cable alignment. For cables up to Ø 1.5 mm, Art. no. 193.005.373

2 Hinged tensioner cone

With conical cap, Art. no. 193.005.374

3 Hinged tensioner cylinder

With cylindrical cap, Art. no. 193.005.375



4 Hinged holder type 15 ellipse

Suitable for vertical, horizontal and diagonal applications; with free-wheeling hub for cable alignment; with elliptical cap, Art. no. 193.005.370

5 Hinged holder type 15 cone

With conical cap, Art. no. 193.005.371

6 Hinged holder type 15 cylinder

With cylindrical cap, Art. no. 193.005.372



Suspension from ceilings

► Ceiling attachments



1 Ceiling attachment M8x1

Combination of ceiling attachment M8x1 with coupling thread M6i and screw-cap M8x1. Diameter 9 mm; flange diameter 11 mm; overall length 16 mm.
Art. no. 193.001.380



3 Sloped-ceiling attachment, small

Combination of spherical cap, small, and ceiling plate with coupling thread M6i. Diameter 15 mm; overall length 21 mm; width of slit 2.1 mm.
Art. no. 193.000.177



2 Ceiling attachment M10x1

Combination of ceiling attachment M10x1 short, with coupling thread M6i and screw-cap M10x1. Diameter 12 mm; flange diameter 16 mm; overall length 17 mm.
Art. no. 193.000.116

Notice: Minimum diameter of terminal on vertical cable = 3.2 mm.



4 Ceiling attachment ellipse

Combination of ceiling attachment ellipse and ceiling plate M10x1 with coupling thread M6i. Diameter 14 mm tapering off to 6 mm; flange diameter 20 mm, overall length 42 mm.
Art. no. 193.005.441



Suspension from ceilings

► Tracks and tensioners

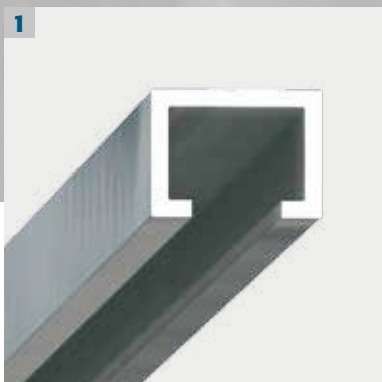

1 Ceiling- / Floor track

Installation on or under plaster, aluminum profile 20x15mm, length 500mm, individually cut to length on demand. Art. no. 029.005.247

Making maximum use of available space

Gallery tracks even allow you to hang exhibits right in the middle of available space, resulting in more room for further exhibits. Gallery tracks can be installed directly on finished ceiling plaster; or – when planned for ahead of time – they can also be discretely installed under it.



2 Tensioner cone

Insertion into ceiling track; horizontally adjustable, for cables up to Ø 1.5 mm; Art. no. 193.005.457



3 Tensioner cylinder

Insertion into ceiling track; horizontally adjustable, for cables up to Ø 1.5 mm; Art. no. 193.005.458



4 Tensioner ellipse

Insertion into ceiling track; horizontally adjustable, for cables up to Ø 1.5mm; Art. no. 193.005.449

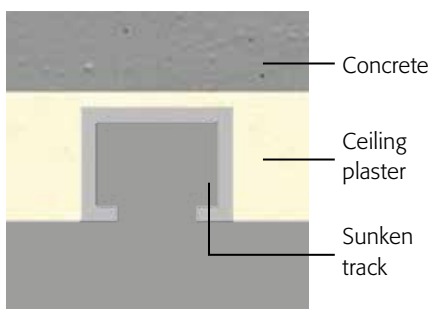

Track under ceiling plaster

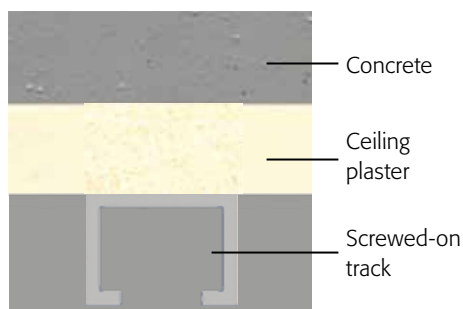

Track directly on ceiling plaster

Notice:

In the case of installation under ceiling plaster – or when track ends are not easily accessible (installation from wall to wall) – an additional bore is necessary for the insertion of tensioners.



Coupling with hook on objects with horizontal cable; see page 18



Coupling with holder Bo on back of object; see page 18



Coupling with hinged holder on side of object; see page 18

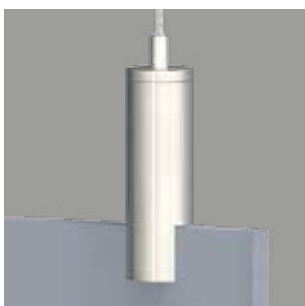

Coupling with holder Top, clamped onto object or frame; see page 19



Tensioning between ceiling and floor

► Tracks, tensioners and holders

In the middle of the room. Yet safe.

By using tensioners between ceiling and floor, a large amount of further exhibition space is gained. Furthermore, tensioning has the advantage of preventing most horizontal movement.

Notice: illustration in reduced size; for actual size see page 9

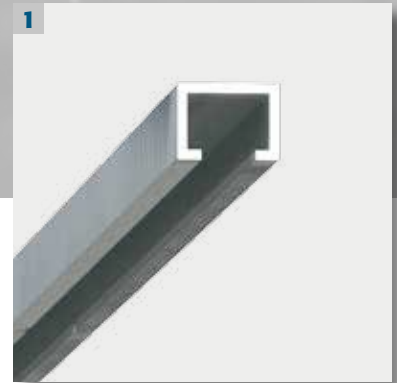

1 Ceiling- / Floor track

Attachment on or under plaster*, aluminum profile 20x15mm; length 500mm, Art. no. 029.005.247, individually cut to length on demand



2 Tensioner cone

Insertion into ceiling track, horizontally adjustable, for cables up to Ø 1.5 mm. Art. no. 193.005.457



3 Tensioner cylinder

Insertion into ceiling track, horizontally adjustable, for cables up to Ø 1.5 mm. Art. no. 193.005.458



4 Tensioner ellipse

Insertion into ceiling track, horizontally adjustable, for cables up to Ø 1.5 mm. Art. no. 193.005.449



5 Holder type 15 cone

Insertion into ceiling track, horizontally adjustable, for cables up to Ø 1.5 mm. Art. no. 193.005.447



6 Holder type 15 cylinder

Insertion into ceiling track, horizontally adjustable, for cables up to Ø 1.5 mm. Art. no. 193.005.448



7 Holder type 15 ellipse

Insertion into ceiling track, horizontally adjustable, for cables up to Ø 1.5 mm. Art. no. 193.005.446

* see notice page 10

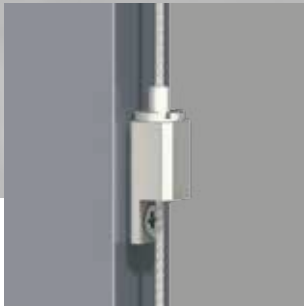

Coupling with holder Bo on back of object. See page 18



Coupling with holder Side on frame or object. See page 19

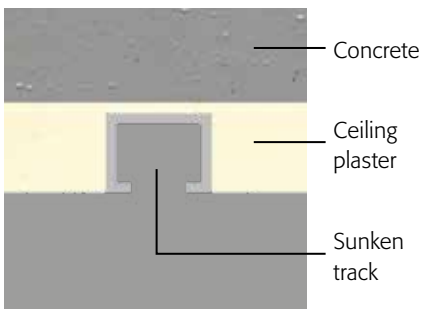

Ceiling track installed under plaster

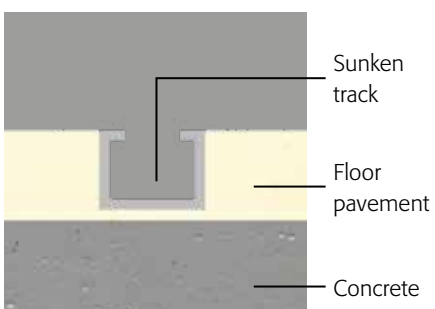

Floor track pre-installed in floor pavement



Tensioning between ceiling and floor

► Tensioners and holders



1 Tensioner cone

Suitable for vertical and horizontal applications; with free-wheeling hub for cable alignment, and with conical cap. Art.no. 193.005.329

2 Tensioner ellipse

With elliptical cap. Art. no. 193.005.330

3 Tensioner cylinder

With cylindrical cap. Art. no. 193.005.331

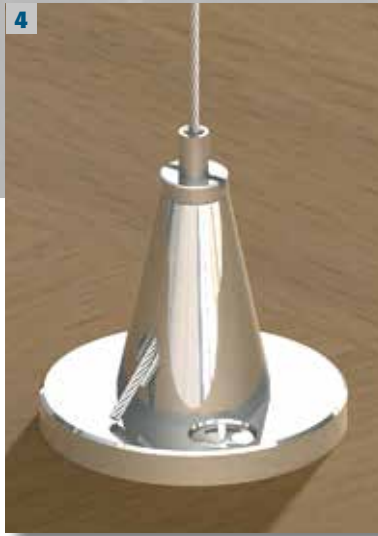

4 Holder type 15 cone

Suitable for vertical and horizontal applications; with free-wheeling hub for cable alignment, and with conical cap. Art.no. 193.005.328

5 Holder type 15 ellipse

With elliptical cap. Art. no. 193.005.333

6 Holder type 15 cylinder

With cylindrical cap. Art. no. 193.005.334



Coupling with holder Side, see page 19

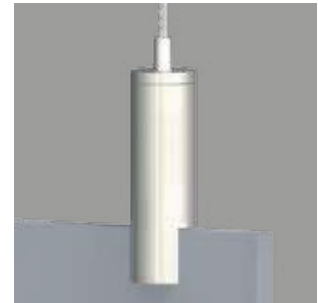

Coupling with holder Top, see page 19



Coupling with holder Bo, see page 18

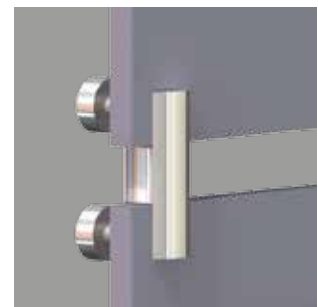

Coupling with vertical connector, see page 20

Notice:

Tensioners can also be used for suspension from ceilings.

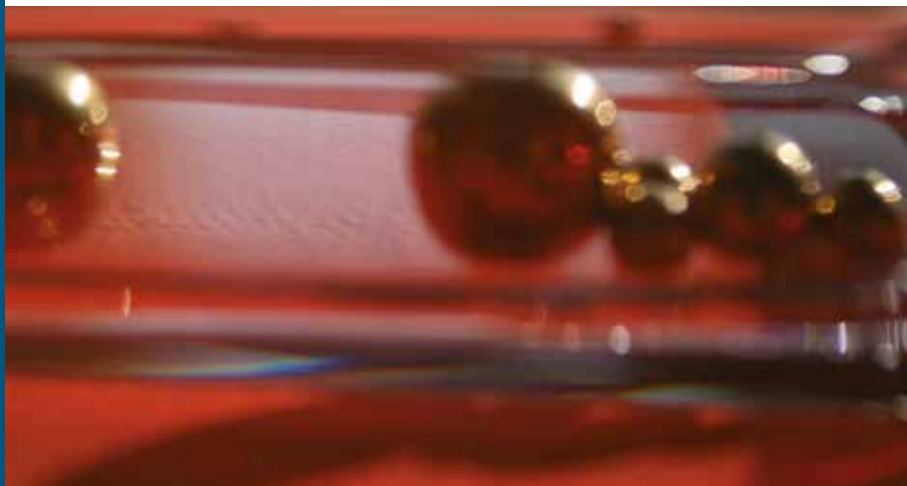

► Application examples

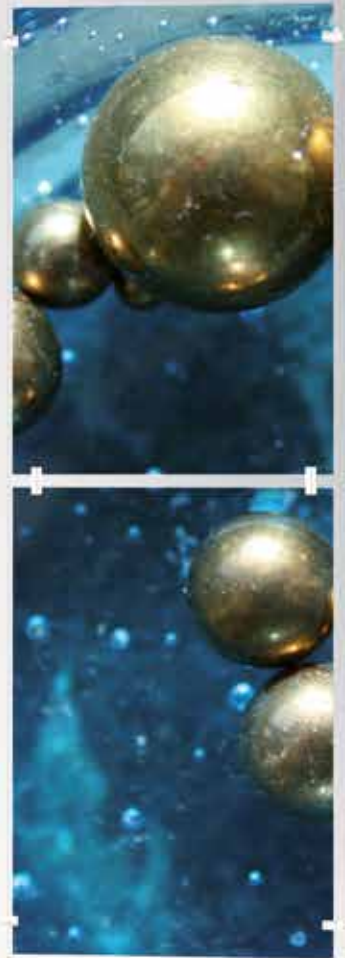

Coupling of cable and object

► Application examples

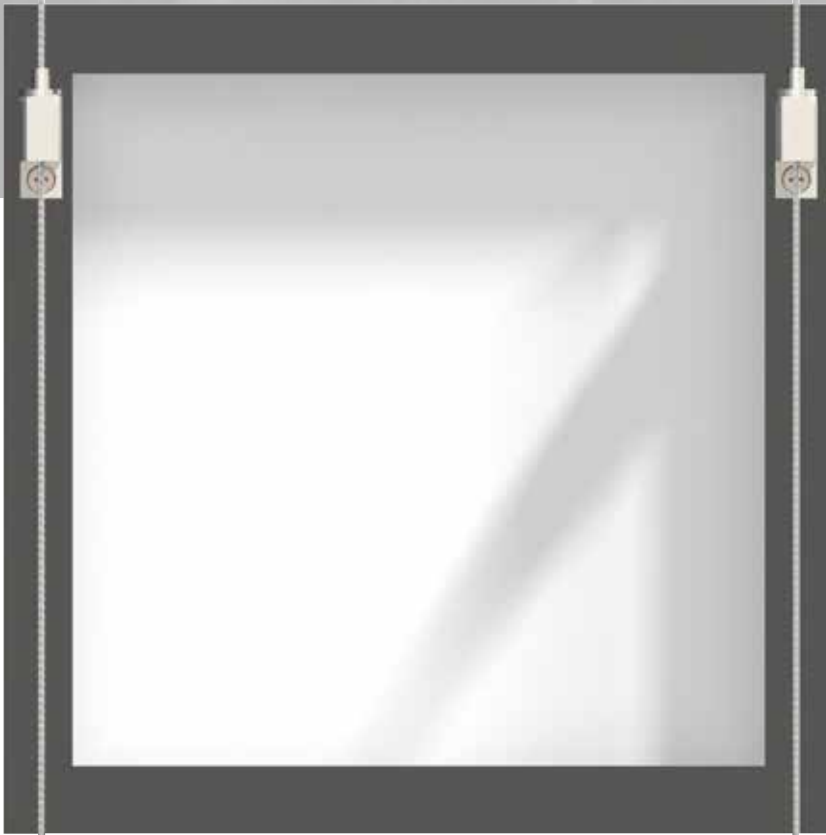

Hook hung into eyelet, attached onto frame



Holder Top on displayed object

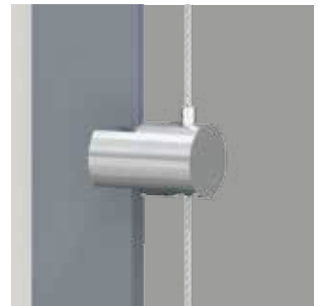

Holder Side on displayed object



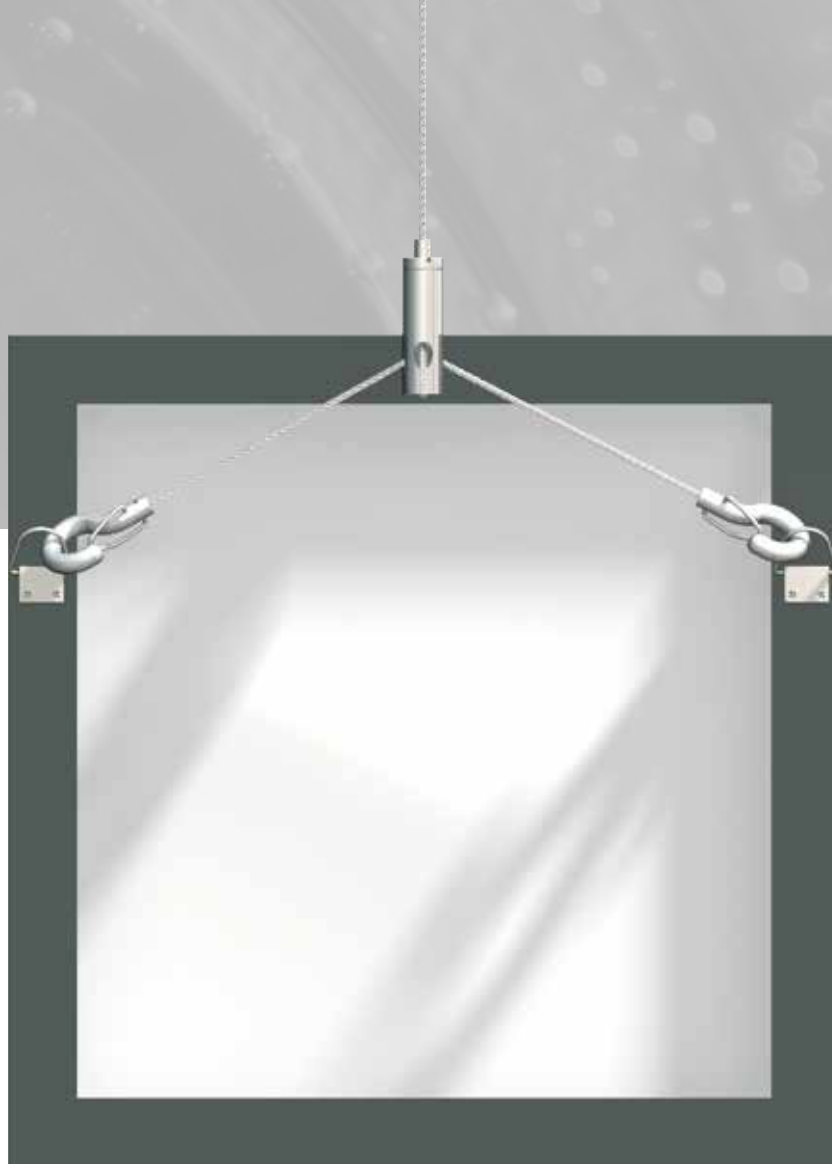

Hook with safety-latch hung into eyelet; eyelet attached onto frame



Holder Bo „loosely“ attached onto back of frame (slanted; parallel to horizontal cable)



Ball sleeve with shaft for „keyhole“ on back of frame

Coupling of cable and object

► Hooks and cable holders



1 Holder type 10 hook

Diameter 9 mm, length 20 mm,
for cable Ø 1.0 mm
Art. no. 193.008.001



2 Safety design holder type 15 hook

With safety-latch, for cables
up to Ø 1.5 mm
Art. no. 193.001.400



3 Holder type 15 hook

Suspension of horizontal cable or
latch; vertical cables up to
Ø 1.5 mm; working load 15 kg;
Art. no. 193.000.163



4 Safety design holder type 18 hook

With safety-latch,
for cables up to Ø 2.0 mm
Art. no. 193.001.512



5 Gallery holder type 15 Bo3

Attaches to vertical frame
components; for vertical cables
up to Ø 1.5 mm; bore Ø 3.2 mm.
Art. no. 193.000.147 ¹⁾



6 Gallery holder type 18 Bo4

Attaches to vertical frame
components; for vertical cables
up to Ø 2.0 mm; bore Ø 4.2 mm.
Art. no. 193.000.015 ¹⁾



7 Hinged holder type 15 ZW M4

For cables up to Ø 1.5 mm;
coupling part with interior thread
M4i; usable thread depth 4 mm. ²⁾
Art. no. 193.000.194



8 Hinged holder type 18 ZW M5

For cables up to Ø 1.8 mm;
coupling part with interior thread
M5i; usable thread depth 5 mm. ²⁾
Art. no. 193.000.063

Coupling of cable and object

► Display holders and cable guides



1 Display holder type 15 Top 65

For attachment to objects up to 6 mm thickness; height 38 mm; diameter 12 mm; working load 20 kg. Art. no. 193.005.352

2 Display holder type 15 Top 105

For attachment to objects up to 10 mm thickness; height 42 mm; diameter 16 mm; working load 20 kg. Art. no. 193.005.353



3 Display holder type 15 Side L 65

For lateral attachment to left side of objects up to 6mm thickness. Art. no. 193.001.378

4 Display holder type 15 Side L 105

For lateral attachment to left side of objects up to 10mm thickness. Art. no. 193.001.378



5 Display holder type 15 Side R 65

For lateral attachment to right side of objects up to 6mm thickness. Art. no. 193.001.377

6 Display holder type 15 Side R 65

For lateral attachment to right side of objects up to 10mm thickness. Art. no. 193.001.375

Chose (almost) any coupling

There are a wide variety of techniques for coupling exhibited objects with tensioned or suspended vertical cables.

Which combinations are possible?

Not all suspensions and/or tensionings can be combined with just any cable holder. Recommended combinations are shown on the chart on page 21.

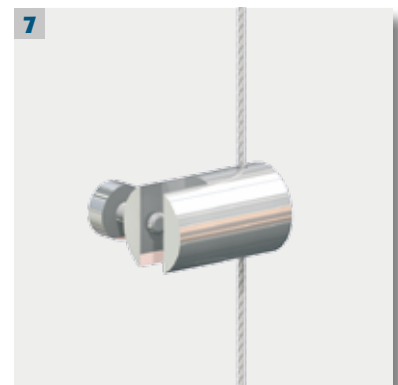

7 Cable guide Side LR 65 ³⁾

For left and right cable guiding of objects up to 6mm thickness. Art. no. 193.005.472

8 Cable guide Side LR 105 ³⁾

For left and right cable guiding of objects up to 10mm thickness. Art. no. 193.005.473



Notice:

- 1) Safety screw not included.
- 2) Optionally, hinged holder type 15 ZW is available with coupling threads M4i, M5i or with exterior threads. Type 18 ZW is available with coupling threads M4i, M5i, M6i, M8i, or with exterior threads. Please enquire.
- 3) Cable guides Side are intended only for securing the lower end of exhibits on vertical cables, and can be used only in combination with the corresponding holder Side.

Coupling of cable and object

► Display connectors and cable connections

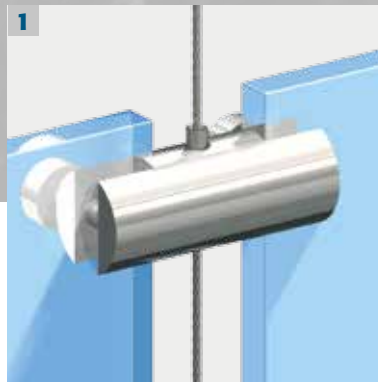
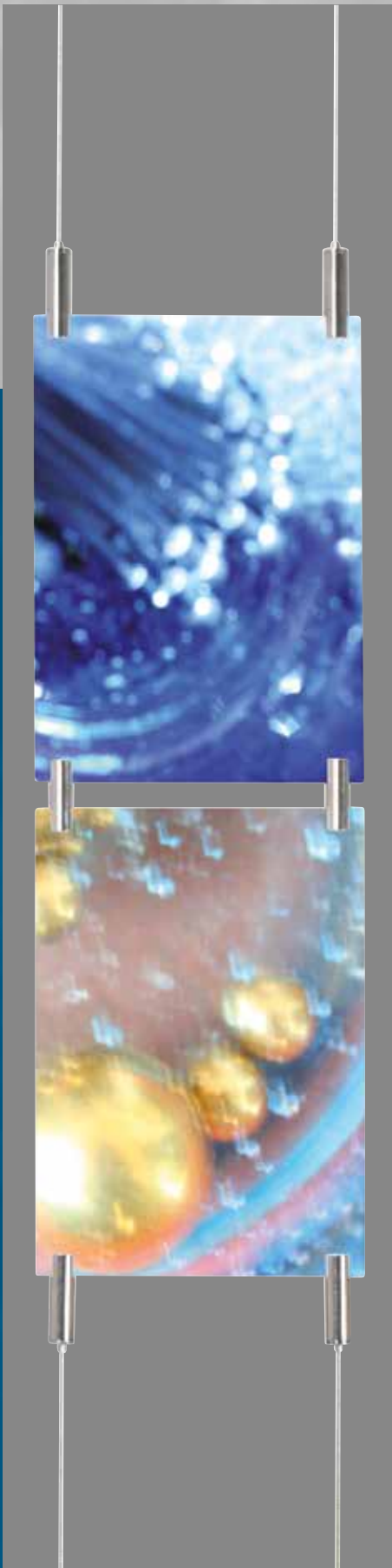

1 **Display holder type 15 Center 65**

For the horizontal connection of objects up to 6 mm thickness.
Art. no. 193.001.073

2 **Display holder type 15 Center 105**

For the horizontal connection of objects up to 10 mm thickness.
Art. no. 193.001.072

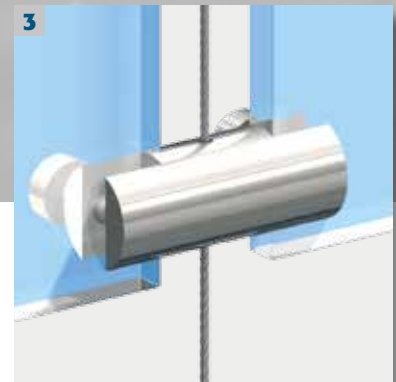

3 **Cable guide center 65***

For the guiding of cables between objects up to 6 mm thickness and cables up to Ø 1.5 mm.
Art. no. 193.006.005

4 **Cable guide center 105***

For the guiding of cables between objects up to 6 mm thickness and cables up to Ø 1.5 mm.
Art. no. 193.006.006

* **Notice:**

Cable guides Center are intended only for securing the lower end of exhibits on vertical cables, and can be used only in combination with the corresponding holder Center.

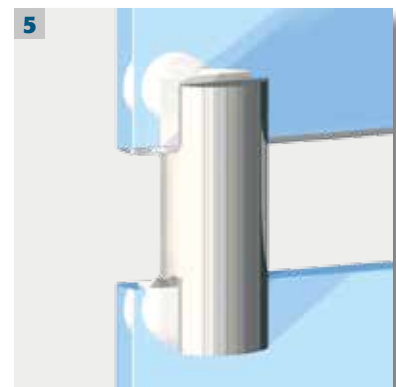

5 **Connecting fork Top 65**

For the vertical connection of objects up to 6 mm thickness, with 2 set screws and two securing screws; Art. no. 193.006.004

6 **Connecting fork Top 105**

For the vertical connection of objects from 6 mm up to 10 mm thickness, with 2 set screws and two securing screws;
Art. no. 193.006.003

Coupling of cable and object

► Overview of coupling varieties

Type of cable attachment ►	Suspensions						Tensioners			
	On the wall				From the ceiling		Wall	Ceiling/Floor		
	Single-unit gallery track	Two – part gallery track	Tensioner top	Ceiling attachment	Ceiling track	Tensioner top	Ceiling-/floor track	Ceiling-/floor track	Tensioner top/holder bottom	
▼ Coupling on cable										
Holder type 10 Hook	●	●	●	●	●	●				20
Safety design holder type 15	●	●	●	●	●	●				20
Holder type 15 Hook	●	●	●	●	●	●				20
Safety design holder type 18	●	●	●	●	●	●				20
Holder type 15ZW Cone	●	●	●	●	●	●				20
Holder type 18ZW Cone	●	●	●	●	●	●				20
Gallery holder type 15 Bo3	●	●	●	●	●	●	●	●	●	20
Gallery holder type 18 Bo4	●	●	●	●	●	●	●	●	●	20
Display holder type 15 Top 65	●	●	●	●	●	●	○	○	○	21
Display holder type 15 Top 105	●	●	●	●	●	●	○	○	○	21
Display holder type 15 Side L65/L105							■	■	■	21
Display holder type 15 Side R65/R105							■	■	■	21
Cable guide type 15 Side LR65/LR105							■	■	■	21
Display holder type 15 Center 65/105							■	■	■	22
Cable guide type 15 Center 65/105							■	■	■	22
Forked connector type 15 Top 65/105	●	●	●	●	●	●	●	●	●	22
	4	6	14	15	8	13	10	13	13	◀ Page ▶

- Combinations possible ○ Only usable with two-part tensioning, consisting of tensioning/cable on top and holder Top on upper part of object, and cable/holder on lower part and holder Top on object ■ Can be combined only when display holder Side and cable guide Side are used

Important safety remarks

Only cables complying with DIN EN 12385-4 7x7 should be used in all gallery, museum and exhibition applications. Cables can be galvanized or stainless steel. We recommend not exceeding a working load of 25kg, when using a cable ø 1,5mm. Breaking load equals approximately five-fold load. Impulse loads and vibration can considerably reduce total loadability. The safe transmission of at least WLL to floor and/or ceiling must be assured through the use of proper dowels and screws.

Further safety recommendations are available on our homepage at www.reutlinger.de



The right cable for each application

Two varieties of cable, in three different strengths, plus nylon wire are available, depending on the chosen combination of wall/ceiling attachment and the coupling of cable and exhibit.

The cables are cut to the desired length and fitted with suitable sleeves, providing maximum safety for the exhibited objects, as well as for the visitors of the exhibition.

All REUTLINGER cables are stress-free, not twisted and cut-proof.

Stainless steel cable

Non – rusting and acid-resistant steel cable of medium tensile strength

Galvanized high cable

Steel cable with zinc-plated surface and extra-high tensile strength

Nylon wire

Transparent synthetic wire with low tensile strength

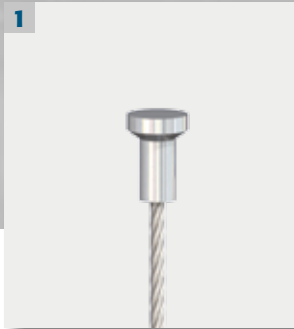

1 T-sleeve 02
Head Ø 6.0 mm
Shaft Ø 3.5 mm
Length 8.5 mm

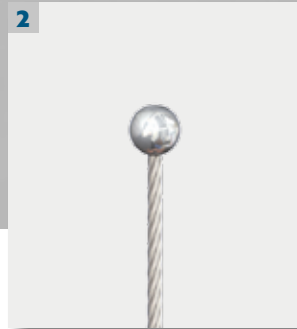

2 Spherical sleeve 36
Ø 5,0 mm



3 Wire eyelet
Ø 6 mm
WLL 10 kg



4 Wire hook
Opening gap 4 mm
WLL 10 kg



5 Wire hook with safety latch
Opening gap 4 mm



6 Cable loop
Dimensions according to drawing



7 Nylon wire loop
For gliding hooks

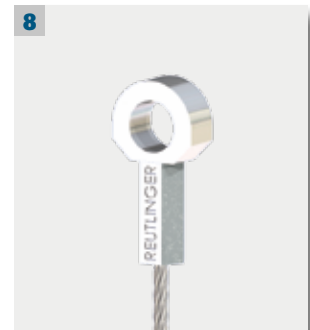

8 Draw-bar eyelet
Ø 5,0 mm



9 Cylinder sleeve
Ø 3,5 mm
length 6,0 mm



10 Cylinder sleeve
Ø 5,0 mm
length 6,0 mm

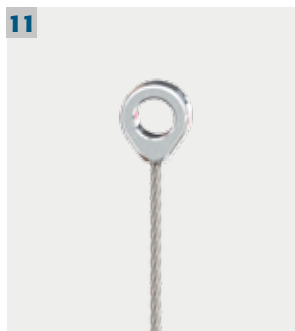

11 Z-eyelet 5 mm
Ø 1,2 mm
length 10,0 mm



12 Z-thimble 6 mm
Ø 1,5 mm

Cables			Terminals (cable ends)											
Cable diameter	Cable material	Cable construction	Illustration											
			1	2	3	4	5	6	7	8	9	10	11	12
1,0	Stainless	6x7+1SE 1.570 N/mm ²	•	•	•	•		•	•	•	•	•	•	•
	Galvanized	6x7+1SE 2.300 N/mm ²	•	•	•	•		•	•	•	•	•	•	•
1,2	Stainless	6x7+1SE 1.570 N/mm ²	•	•	•	•	•	•	•	•	•	•	•	•
	Galvanized	6x7+1SE 2.300 N/mm ²	•	•	•	•	•	•	•	•	•	•	•	•
1,5	Stainless	6x7+1SE 1.570 N/mm ²	•	•	•	•		•	•	•	•	•	•	•
	Galvanized	6x7+1SE 2.300 N/mm ²	•	•	•	•		•	•	•	•	•	•	•
	Nylon								•					



**Please request
the following catalogs:**

Mini

Holders & Accessories
Type 10, 12

Standard

Holders & Accessories
Type 15, 18, 20

Heavy Load

Holders & accessories
Type 25, 30, 50, 80

Shop | Display

Presentation – and Shelving –
Systems for retail applications

**Cable Suspensions for
Event Technology & Rigging**

Type 50, 66, 80

Have we gotten you interested?
Do you have questions concerning
technical details? Please give us a
call!

**Sales & Consultations
Germany (D-A-CH)**

Andreas Mixa
+49 (0) 69 965228-37
a.mixa@reutlinger.de

Hans-J. Arendt
+49 (0) 69 965228-16
hj.arendt@reutlinger.de

Miriam Ansorg-Riedling
+49 (0) 69 965228-70
m.riedling@reutlinger.de

**Sales & Consultations
International**

Silvia Kopka
+49 (0) 69 965228-12
s.kopka@reutlinger.de

Stefanie Händler
+49 (0) 69 965228-18
s.haendler@reutlinger.de

Ana Maria Ruiz
+49 (0) 69 965228-47
am.ruiz@reutlinger.de

Reutlinger GmbH

Offenbacher Landstr. 190
60599 Frankfurt
Germany

Phone +49 (0) 69 965228-0
Telefax +49 (0) 69 965228-30

E-Mail info@reutlinger.de
Internet www.reutlinger.de

Managing Director
Dipl. Ing. Wolf Reutlinger

HRB Frankfurt 33321
USt-ID DE 114 209 718